

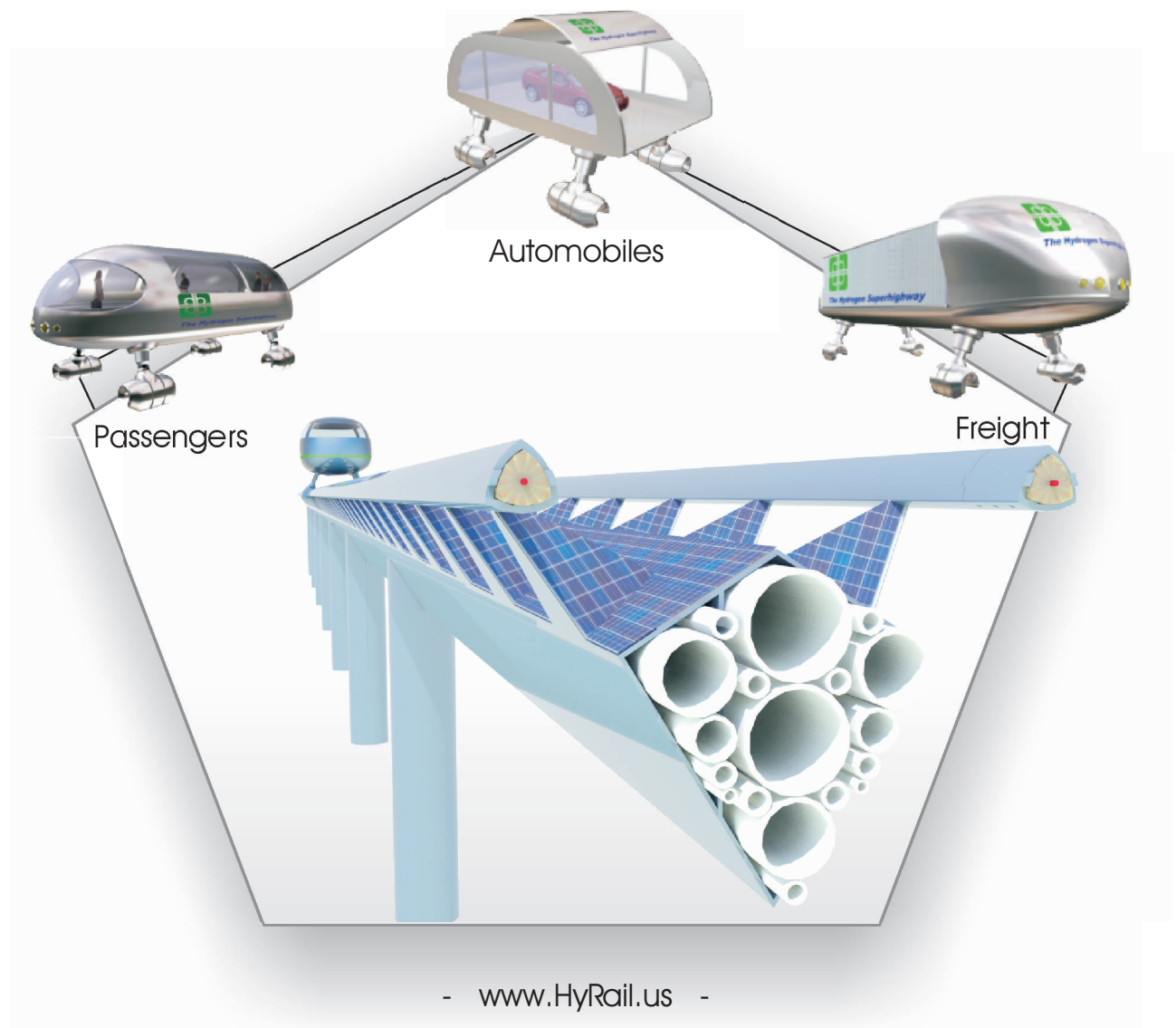

# WORLDWIDE HYDROGEN SUPER HIGHWAYS



- [www.HyRail.us](http://www.HyRail.us) -

- [www.InterstateTraveler.us](http://www.InterstateTraveler.us) -

- [www.ElevatedRailSystems.com](http://www.ElevatedRailSystems.com) -

- [www.HydrogenSuperHighway.com](http://www.HydrogenSuperHighway.com) -

- Copyright 2002-2018 Justin Eric Sutton and Interstate Traveler Company, LLC -



# **HYDROGEN SUPER HIGHWAY**

## **INFORMATION BOOKLET**

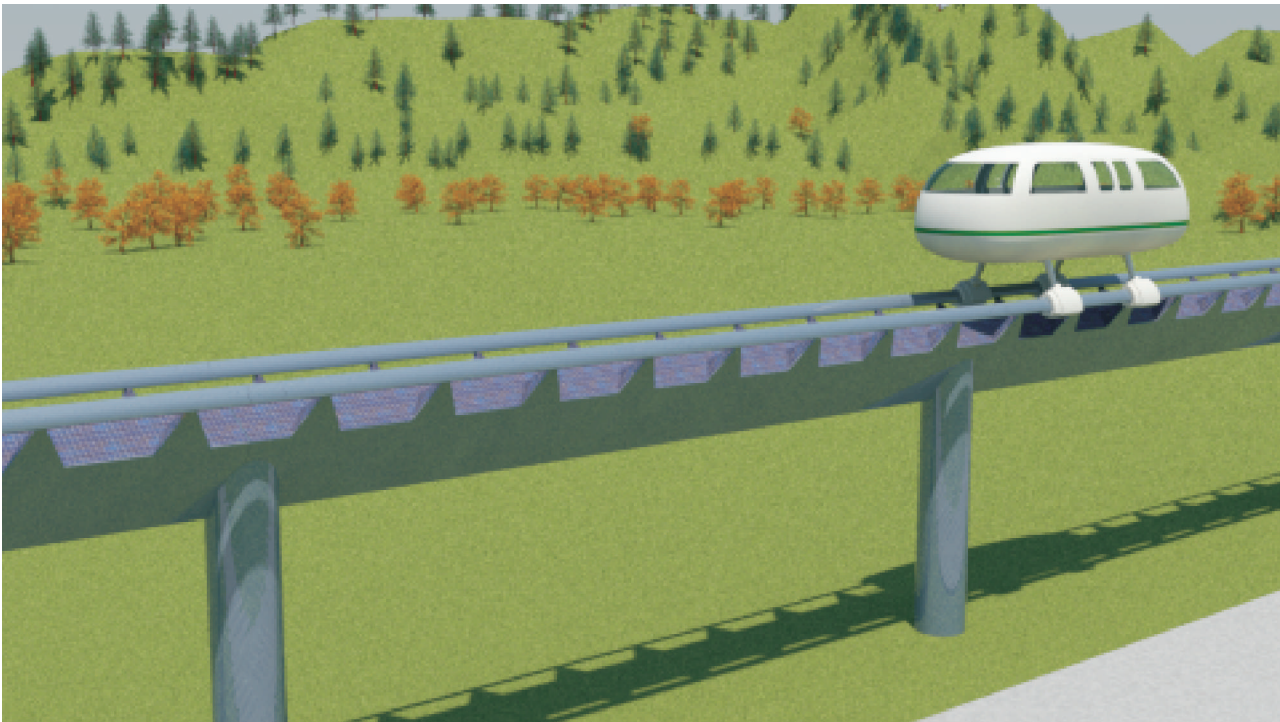

**REVISED JUNE 6<sup>TH</sup> 2018**

**AUTHORED, TYPESET & DESIGNED  
BY**

**JUSTIN ERIC SUTTON**

**EDITED BY**

**JIM M. JUNG CEO**

**MADE POSSIBLE BY THE SUPPORT OF  
THE INTERSTATE TRAVELER COMPANY, LLC  
ALL RIGHTS RESERVED**

# What is the Hydrogen Super Highway?

... It is a collection of vital municipal utilities bundled into a Conduit Cluster providing a first-of-its-kind full integration of solar powered hydrogen production and distribution system technology which provides the energy to operate a high speed magnetic levitation ( MagLev ) 'on-demand' public transit network built along any permissible right of way, private or public, such as highways, local roads, power corridors, the US Interstate Highway Systems, etc., where such a machine would be of benefit.

The Hydrogen Super Highway (HSH) is accessed by people, vehicles and freight through Traveler Stations that are built along permissible rights of way or appropriate real estate providing maximum ease of access.

## *The Hydrogen Super Highway...*

Transportation System

Solar Energy Collection Grid

Intelligent Electrical Distribution

Intelligent Electrical Load Balancing

Hydrogen Production & Distribution

Liquid / Vapor Storage & Distribution

Redundant Fiber Optic Network

Wireless Internet Broadband Access

Embedded Fresh Water Pipeline

Many Thousands of Jobs

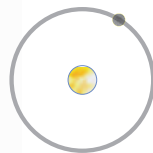

The Hydrogen Superhighway





# The Interstate Traveler

Hydrogen Super Highway - MagLev Public Transit Network

- Fast
- Safe
- Clean
- Quiet
- Quality
- Weather Proof
- Sand / Ice Proof
- Creates Hydrogen
- Creates Clean Water
- Creates & Stores Surplus Power
- Creates Good Paying Long-term Jobs

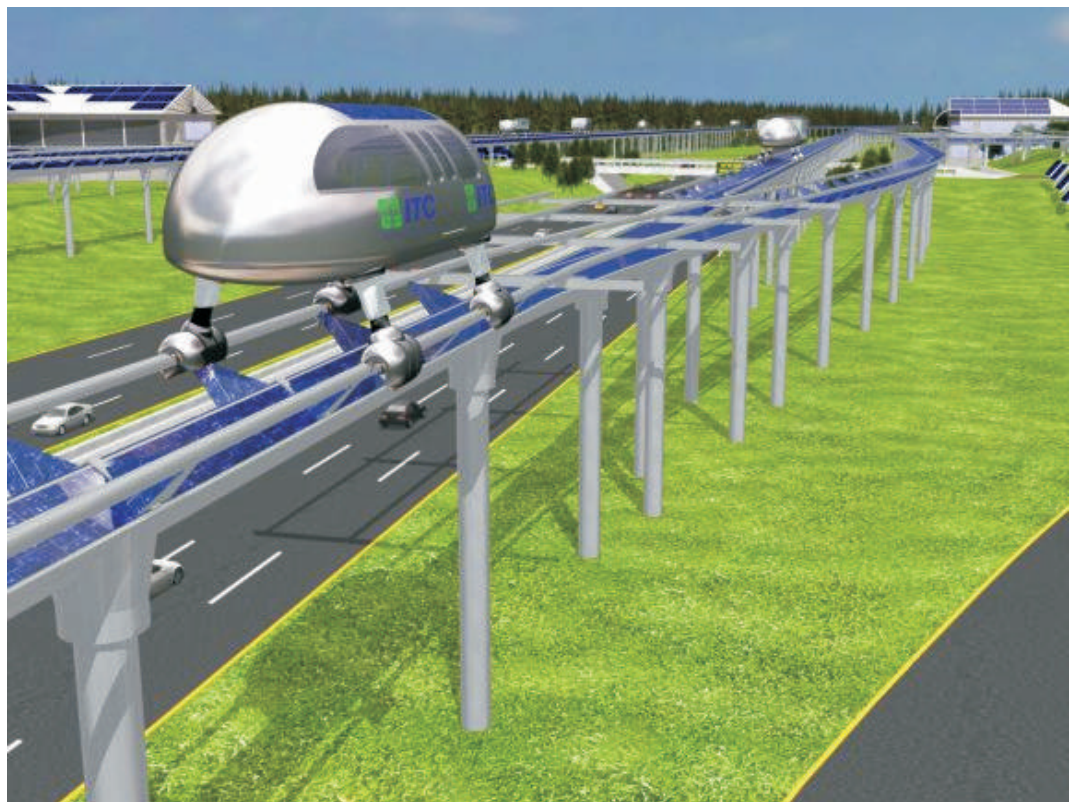
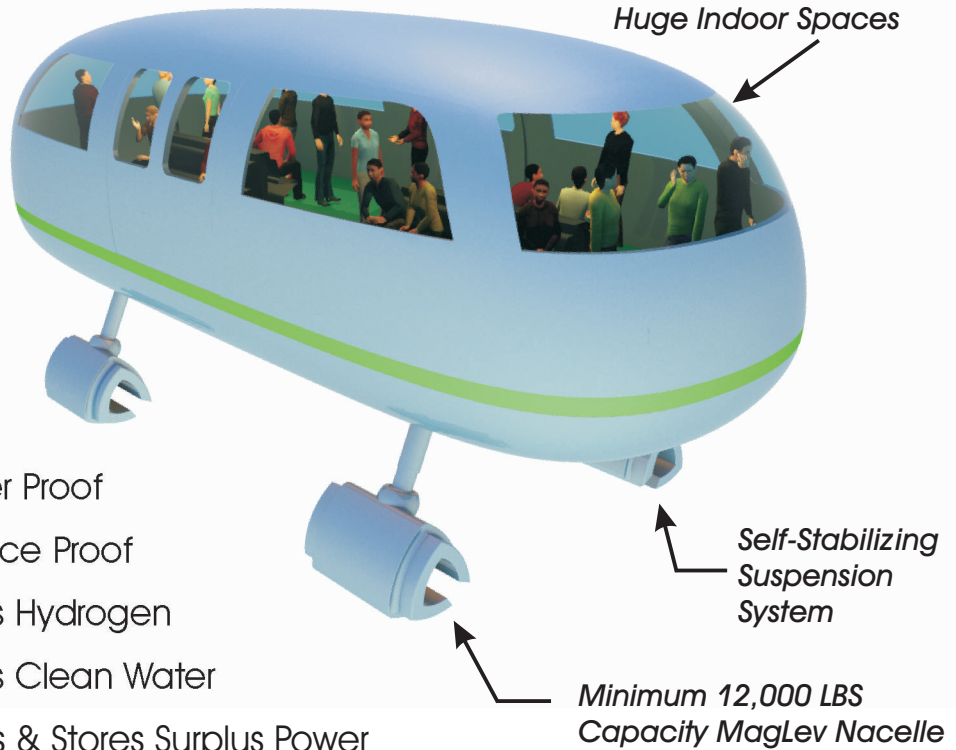

# The Hydrogen Super Highway

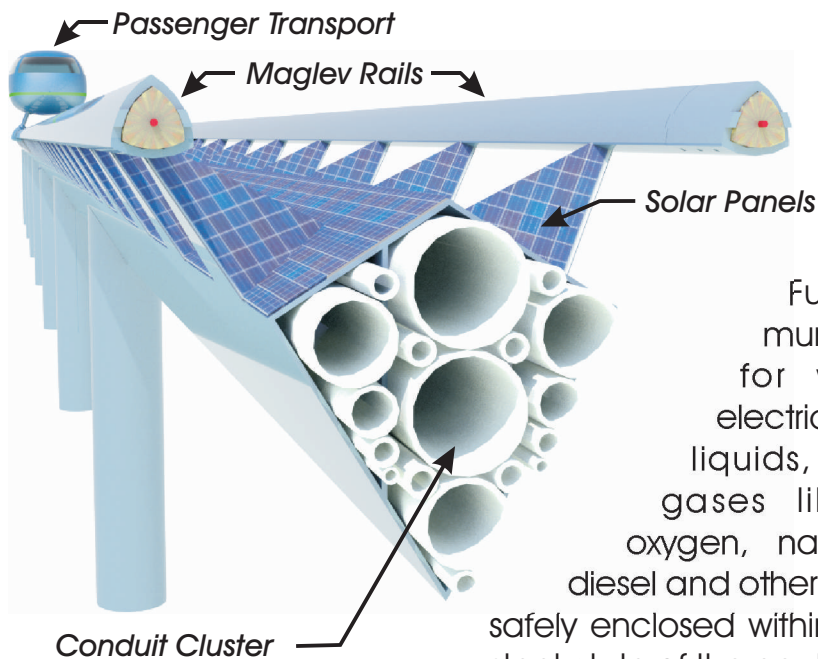

Fully embedded municipal conduit for water, sewer, electricity, fiber optics, liquids, vapors, and gases like hydrogen, oxygen, natural gas, bio-diesel and other types of fuel, all safely enclosed within the protective steel plate of the central support. The

HSH will be able to deliver fuels of all types to filling stations including current gas stations along rights of way saving time and money while increasing distribution reliability and safety.

Best of all, the system will consume liquid waste and generate pure water from Hydrogen.

The Hydrogen Super Highway is ready to serve the growing needs of our nation and of the many nations around the world where infrastructure needs have grown faster than their current infrastructure capabilities.



The HSH bridges the gap of time and distance while creating a far-reaching solar powered, hydrogen production and distribution network. The embedded systems of the Hydrogen Super Highway also create a waste water management system and water purification system that will serve the public for generations to come.





# Ride with Friends

Ride with comfort in the spacious and open cabin area. Enjoy the view out the window as the world slips by at 200+ mph. Like every pilots dream, being able to fly at tree-top level and really enjoy the countryside.



Fast

Reliable

Spacious

Comfortable

On Demand

No other transportation system in the world can give you such a smooth ride and such a priceless panorama of the world around you.

Fixed schedule and on-demand transports means no waiting.

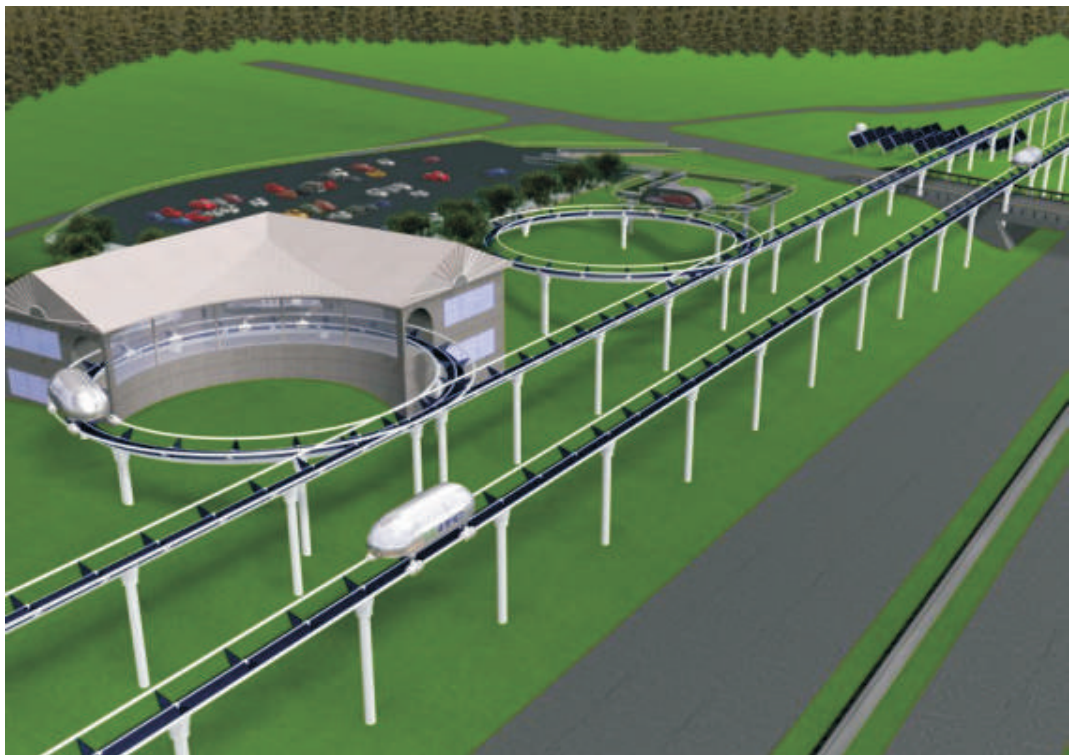
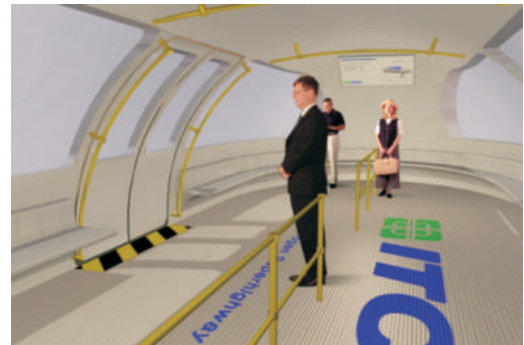

# Ride with Family



The Car Transport is perfect for Family trips over long distances.

On the HSH you will be able to travel with your car, truck or SUV at a high rate of speed. You could even load a bunch of motorcycles for a sunset ride out West or load up the snow mobiles for an afternoon ride 200 miles away.

At 200mph on the HSH, you will be only about an hour away ...

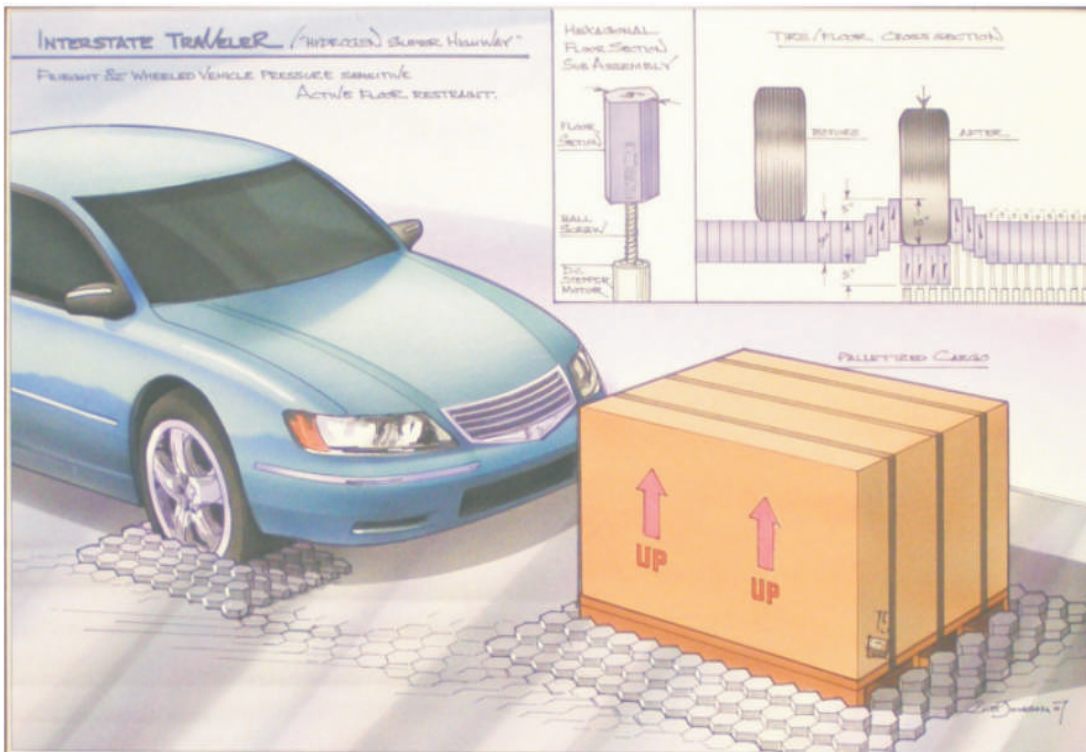
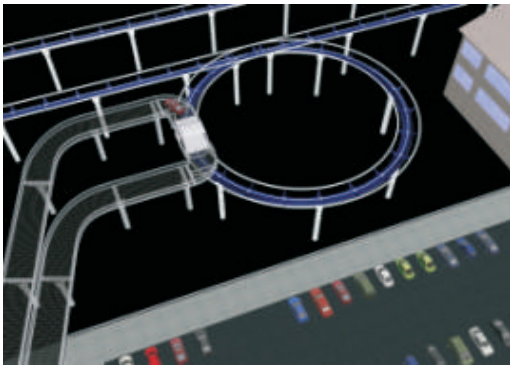

Private

Versatile

Durable

Cars

Trucks

Pallets

Anything





# Ride in Luxury

Office, Condominium, Private Parties

Huge Area

Commercial

Residential

Club Car

Limousine

Sports Teams

V.I.P.s

Never before could it be possible for such large, spacious, and comfortable transport vehicles to be constructed and reliably operated across a national network of high speed, super efficient maglev rail.

In the future, many tens of thousands of Grand Traveler Transports will glide the rails from State to State and from Country to Country, gliding quietly above the tree line.

Boasting a living space of more than 2,000 square feet, the Grand Traveler will be the pallet of automotive designers for years into the future creating all manner of custom spaces.

From Sea to shining Sea, from North to South and from East to West; riding the HSH will always be the best.

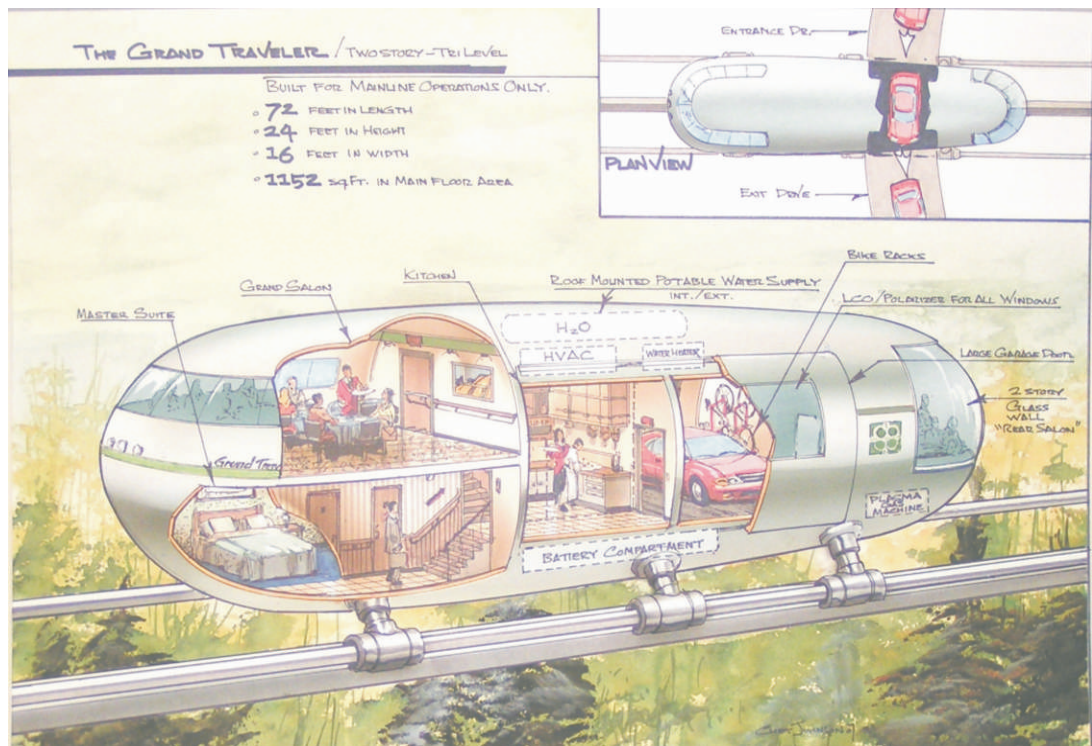
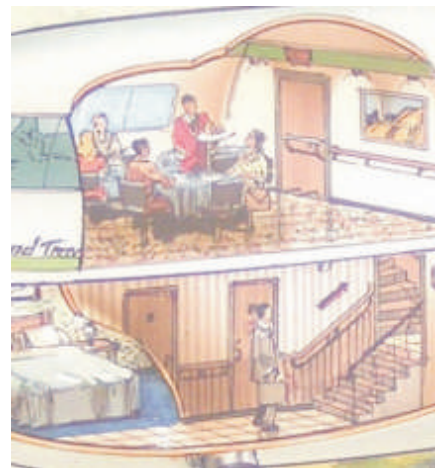



# Sports Model

Able to support 2,000 square feet of space...

Of the many diverse and popular sports and vacation activities, our focus groups suggested we illustrate the system used for a wonderful weekend in the mountains where you can bring a large team of horses and handlers and equipment with you. Pick your favorite sport...

## The Equestrian Explorer

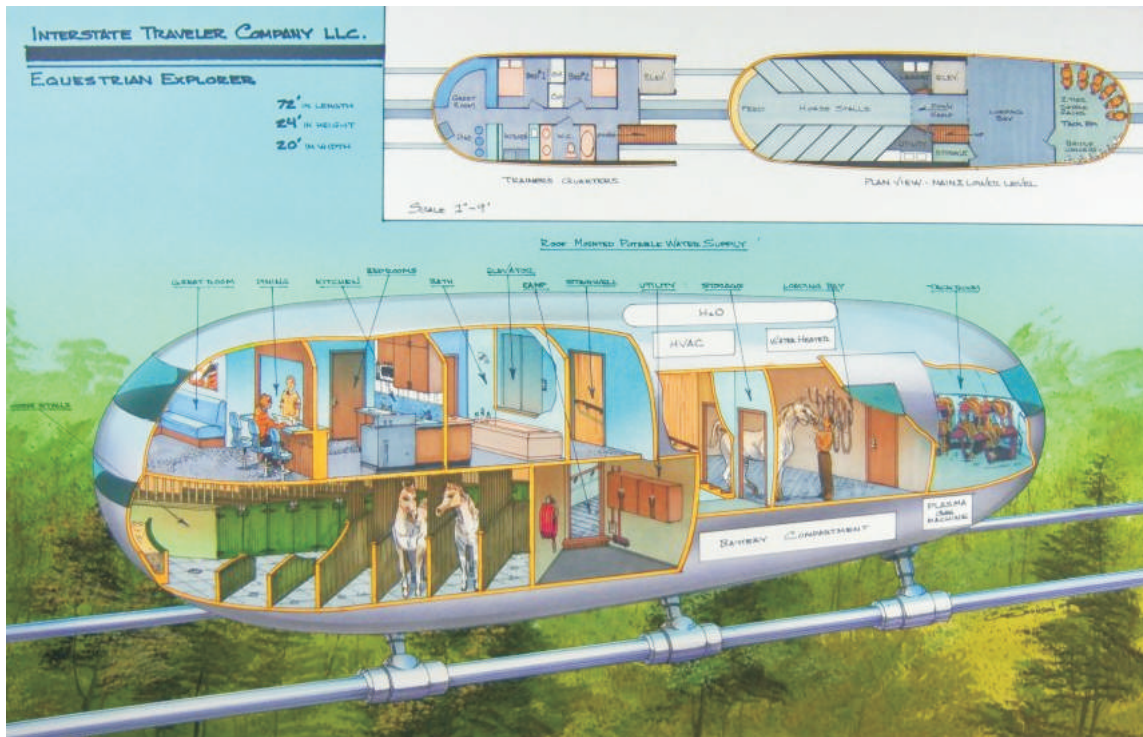
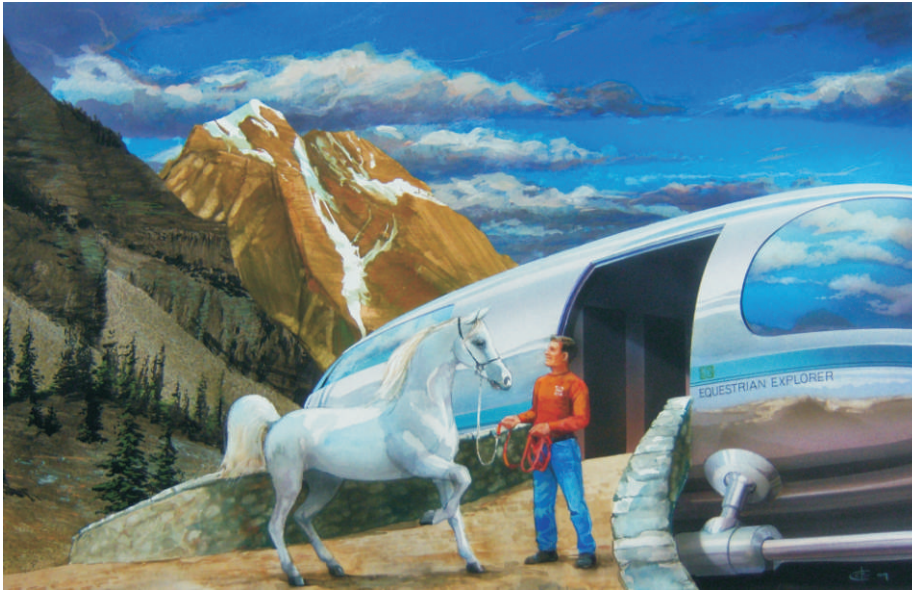

- Horses
- Street Bikes
- Dirt Bikes
- Quad Runners
- Snowmobiles
- Skiing
- Snow Boarding
- Bicycling
- Segways
- Hiking
- Sight Seeing
- Forestry
- Ecology





# Triage Traveler

Medical Staff

Imaging

Chemistry

Anesthesiology

Surgery

Fast Travel

Weather Proof

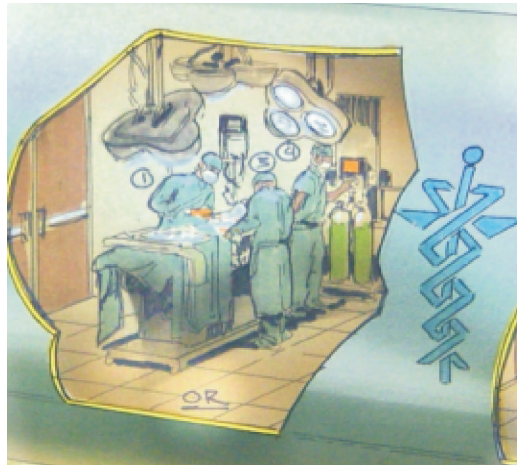

The tragic number of fatalities on American Highways is a harbinger of fate for highways all around the world.

With the Triage Traveler riding on the HSH, we will be there to help save lives.

According to government statistics, more than 35,000 people per year perish on our National Highways alone.

Many of whom could have been saved if they could have gotten to a hospital within that golden hour.

We will be able to assist in more than just accidents on the highway, we will be able to bring expert specialists to any Traveler Station on the network with staff and equipment and on a regular schedule.

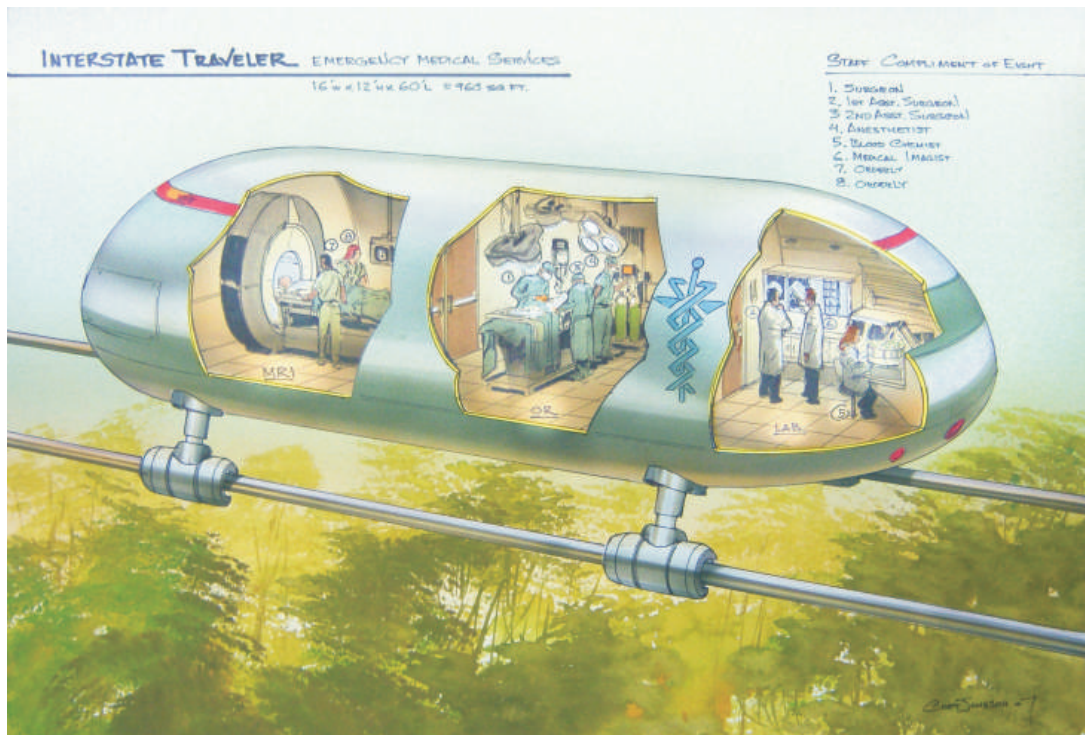

# Rapid Rescue

Quickly rescue injured people

We thank God for the people who dedicate their lives to become paramedics, doctors, fireman and policeman. These brilliant, brave and kind hearted people are who we count on to save us when we are in harms way.

Dedicated to those who answer your call for help, the Interstate Traveler Company will dedicate free access and operation to Paramedical Units like the Triage Traveler.

Many car accidents result in a large number of wounded and often outnumber the first responders 2 and 3 to one. The Triage Traveler will bring a staff of medical professionals to the scene of an emergency to lend much needed support and provide high speed delivery of the critically injured to the nearest hospital or Traveler Station to transfer to a waiting ambulance.

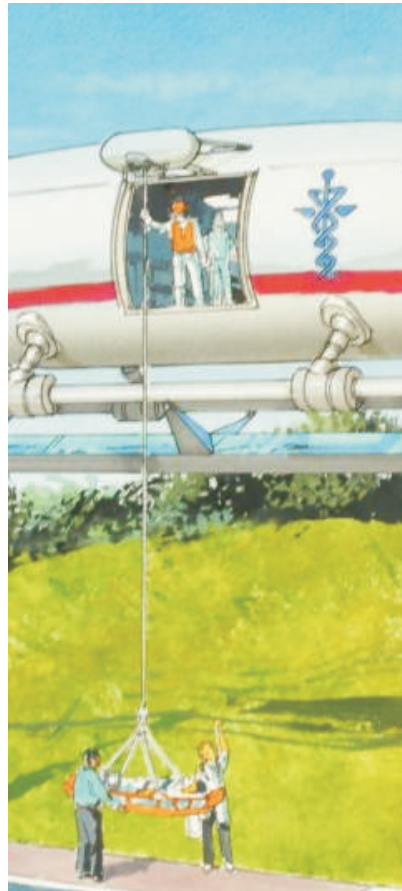

Triage

Surgery

Medicine

Haz-mat

EMS

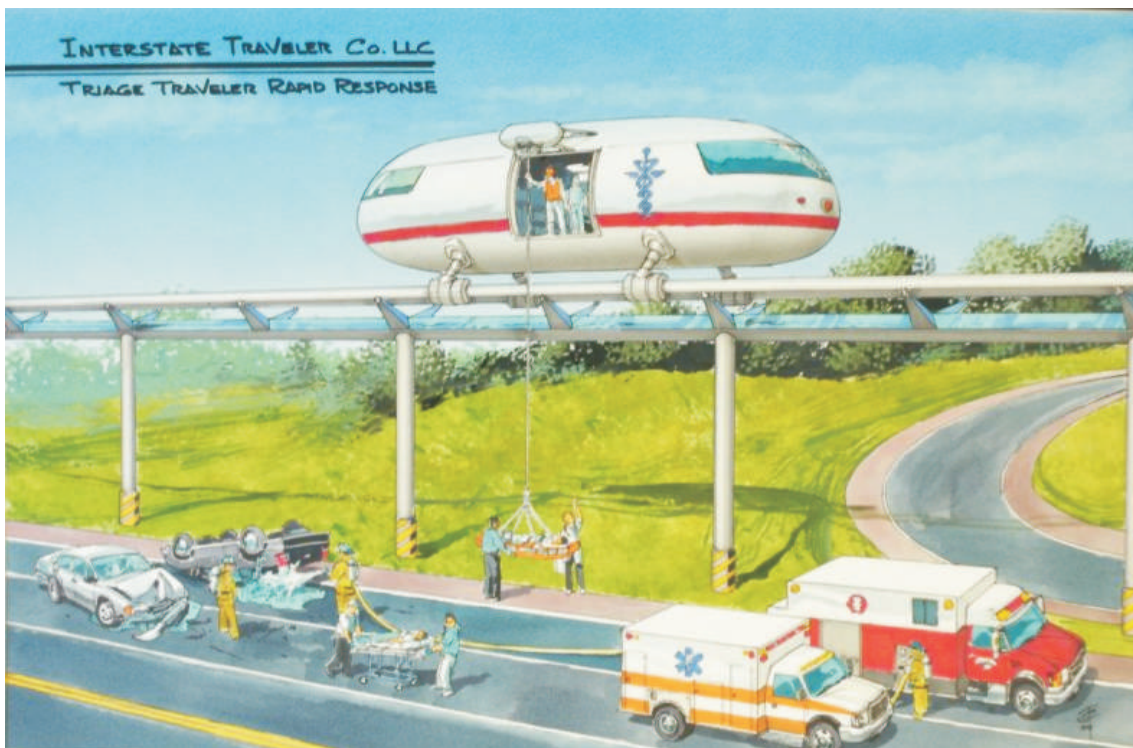



# Highspeed Hospital

The modern world is now the home of more than 7 billion people and we are all connected by road ways that enable commerce to flourish, but the roadways are not completely safe.

Here in America we have a mortality rate of more than 35,000 people a year on our Interstate Highway System alone, with many more on the surface streets.

Just like the Triage Traveler, we can bring the HSH Hospital to places of need *fast*, yet with the added ability to perform complex medical procedures and transport groups of injured people to long term care facilities.

When you are in need, the Highspeed Hospital will be there fast...

Disaster Relief - Mass Casualty Support - Complex Procedures

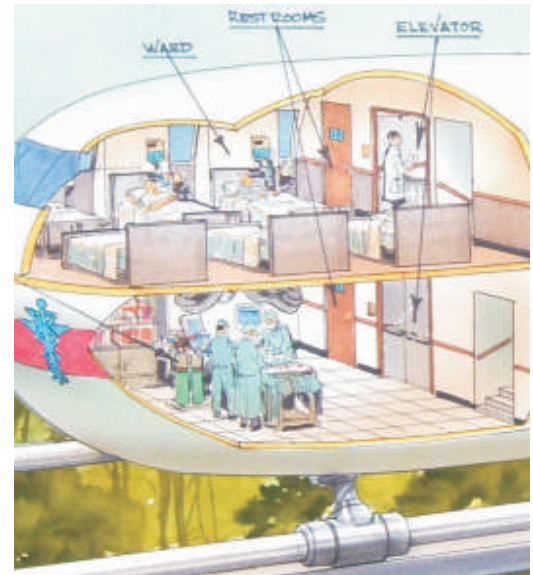

6 Bed Ward

Staff of 12

Onboard Ambulance

Mass Casualty Response

General Practice

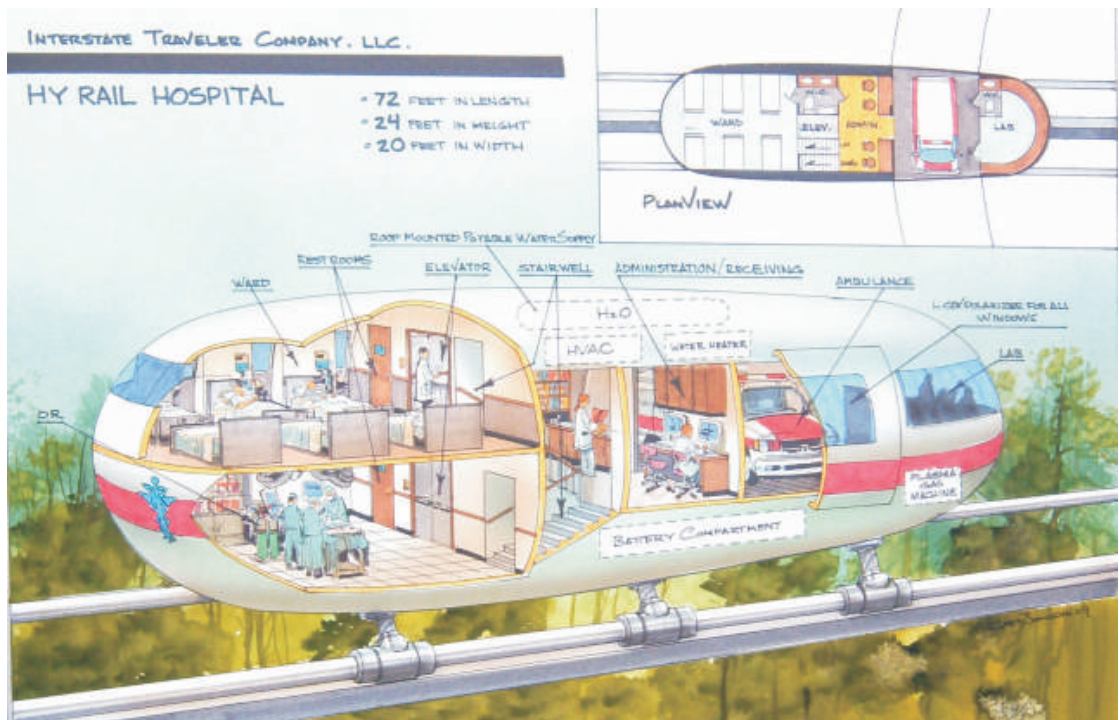

# Wide Doors - Open Spaces

Some of the greatest benefits of the Hydrogen Super Highway are the enormously wide entry doors with huge open spaces and a zero-gap threshold that makes egress with wheel chairs, canes, crutches, walkers, baby strollers and even high heeled shoes practically seamless.



Since the creation of the Americans with Disabilities Act public infrastructure was renewed for the betterment of all people, with or without the need for ramp or hand rail. We are proud of our ability to exceed the current ADA requirements making sure everyone has equal access.

On the HSH, a Traveler will always be at ease and relax in confidence that a Concierge is close by to aid and assist you if you need directions, help with your bags, or in case of a medical emergency.

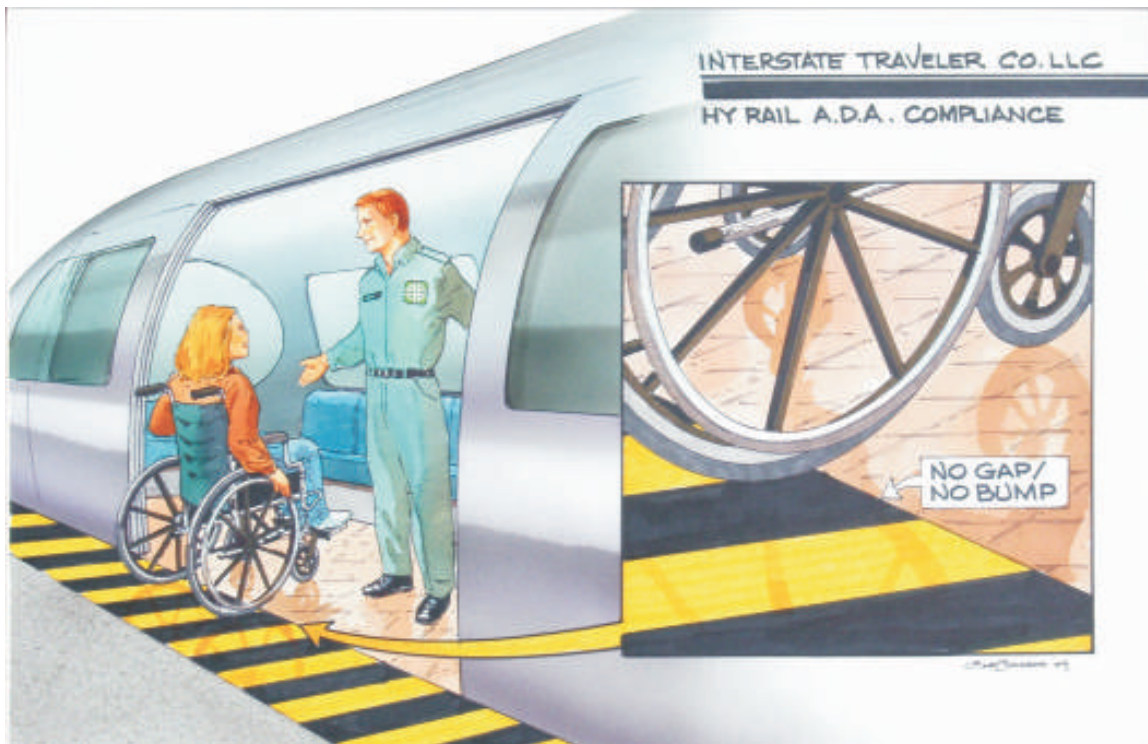

ADA

Compliant

Secure

Reliable

Comfortable

Accessible





# Civic Centers

With the HSH, the clear waters will flow around the clock.

Reaching back to the great architects of the Bath House, the Public Forum and concepts of a public market area of many small shops, we present this integration of the best of the best.

Rest and Refreshment



At the Civic Centers visitors will enjoy the greatest facilities in the world having a Clean, Healthy, Happy and Worldly experience.

The Civic Center is a perfect integration of hospitality and entertainment. With a constant flow of pure water, we will be able to support state of the art public pools, saunas, mineral baths and centers for the finest culinary arts. Each will help create jobs in the massage therapy, physical training, inspired Master Chefs of culinary arts and live entertainment.

Whether you want a hot mineral bath, or a cool lap in the pool... You are just a few minutes down the rail to paradise.



Worldly

Local Flavor

Community

Concerts

Shops

Spas



# The Traveler Station

Key to the success of any public transit system is access.

The Traveler Stations can ensure maximum access points for ease of entry and exit to the HSH system. Traveler Stations will enable ease of access, parking, and amenities that will rival any 'public transit stop' in the world in form and function.

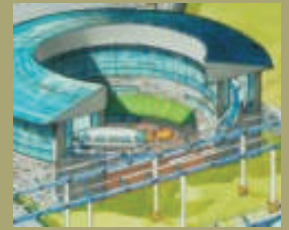
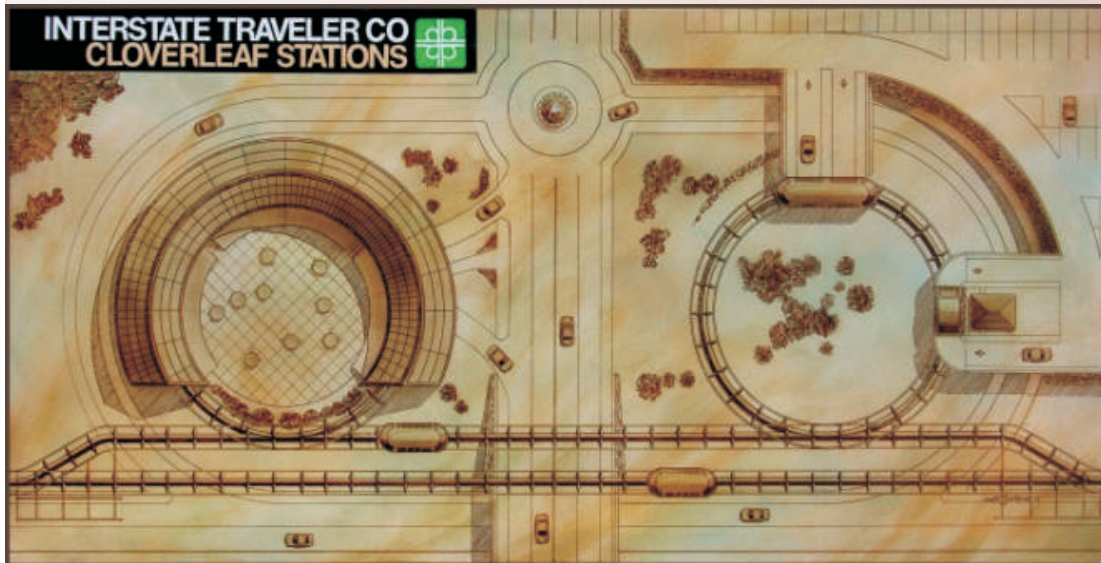
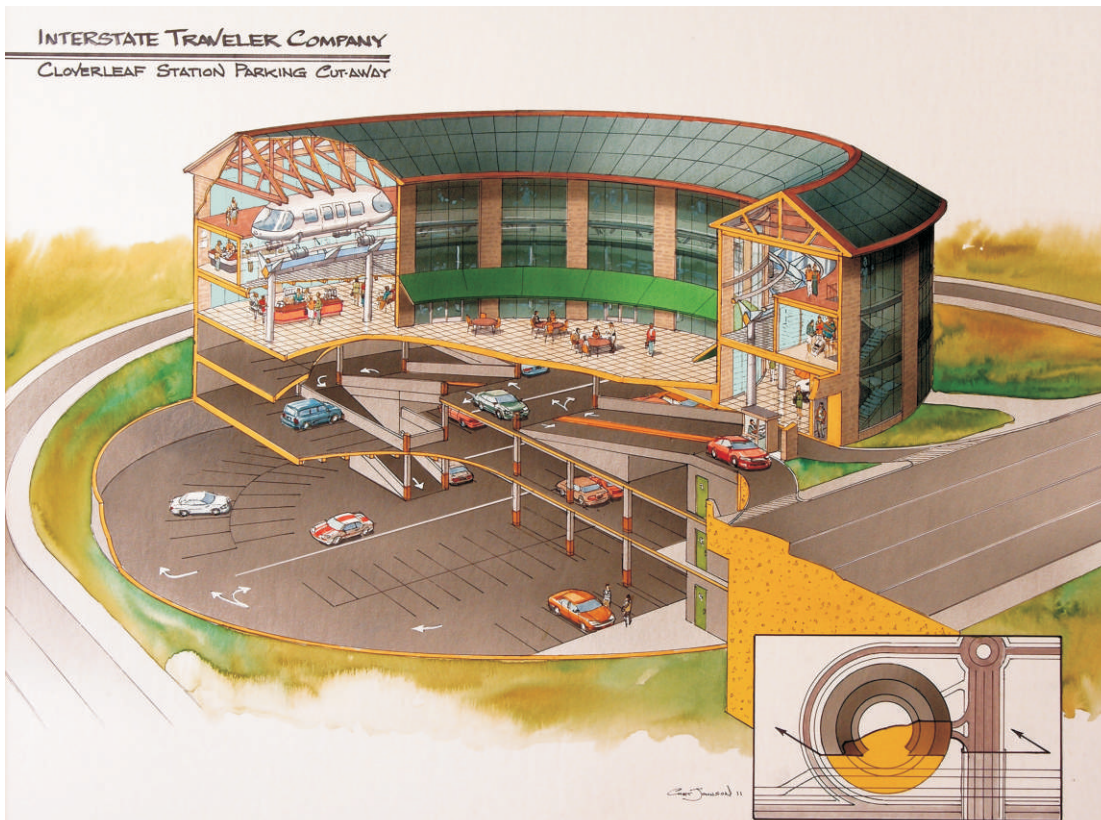

Everywhere

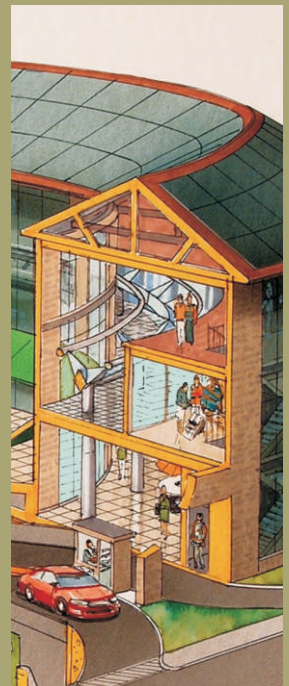



# Solar - Hydrogen Cycle

As our world turns into the light each and every day, so stands the Hydrogen Super Highway to receive the light from the rays of the sun and put it to good use serving millions of travelers around the world.

Bridging the gap of time and distance with municipal scale utility systems, the HSH enables the world to grow into the green economy.

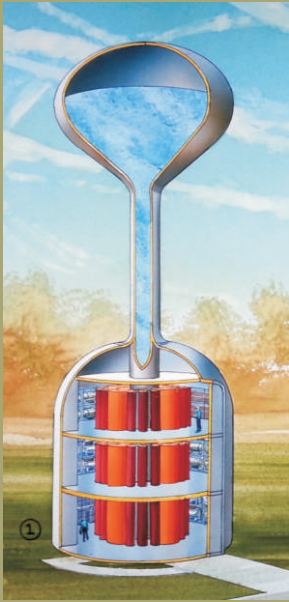

Endless Water

Endless H2

H2 Plasma

High Capacity Energy Storage and Distribution

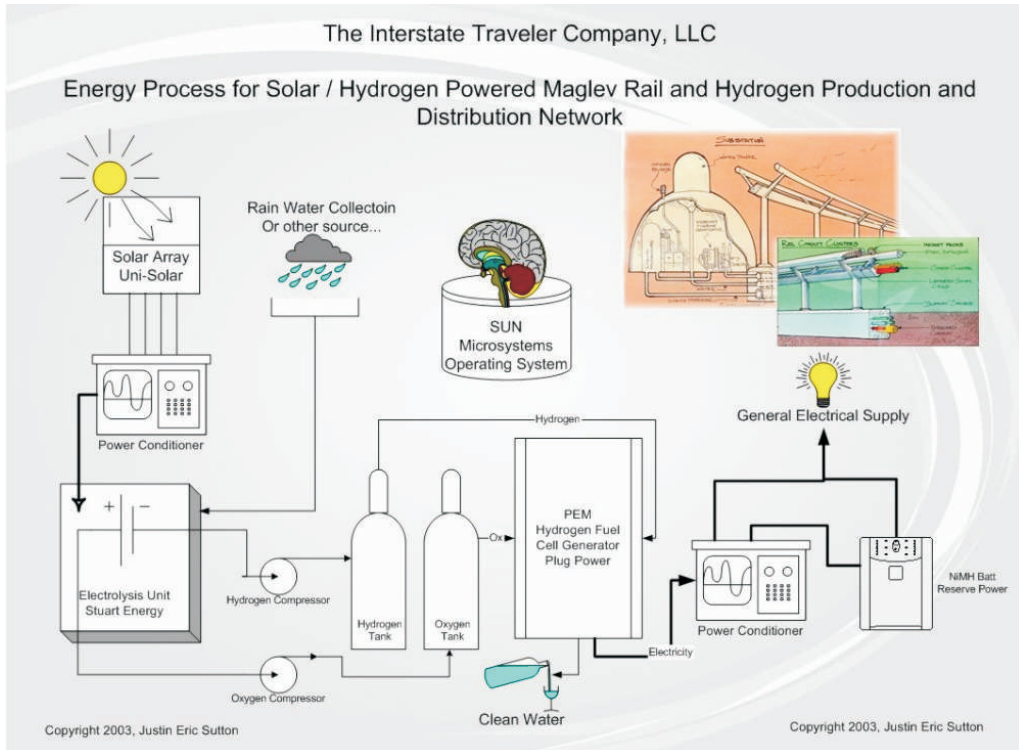
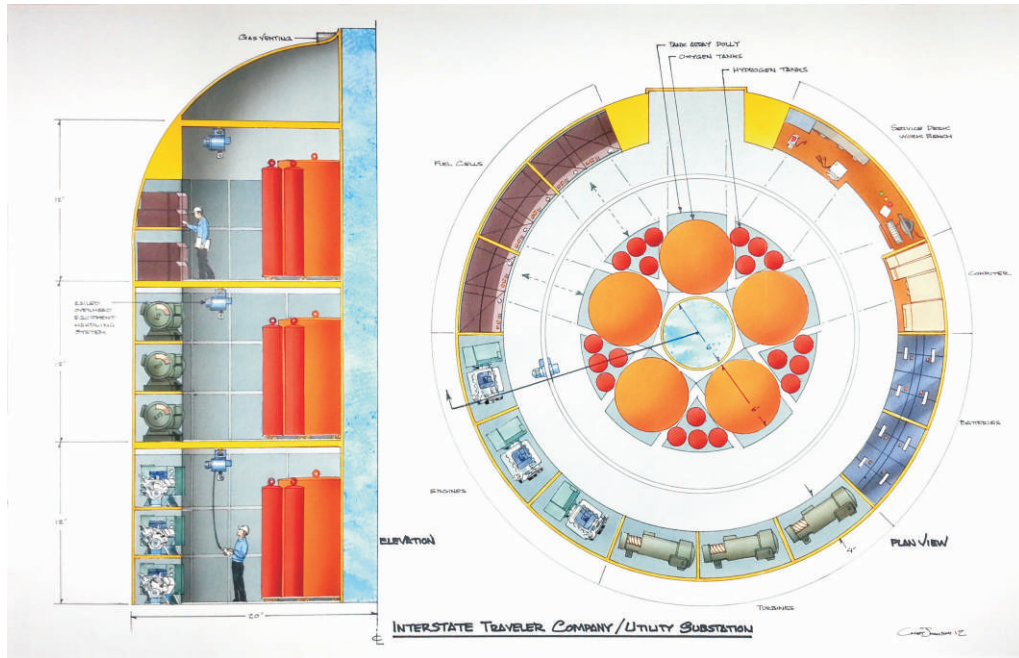



# The Desert Blooms



## Sustainable Agriculture

The ability of the Hydrogen Super Highway to process large volumes of sea water, waste water and sewerage directly enables the support of massive industrial scale hydroponic and aeroponic grow systems for food production that will exceed traditional agricultural methods, bring 'food security' to developing nations and meet the needs of future population growth all around the world. As we look into the future, this may be our most important capacity; we all wake up hungry and thirsty.

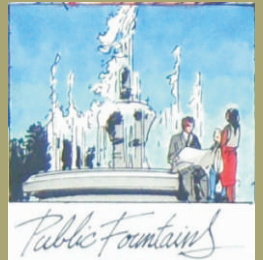

Water

Agriculture

Sanitation

Hydroponics

Aeroponics

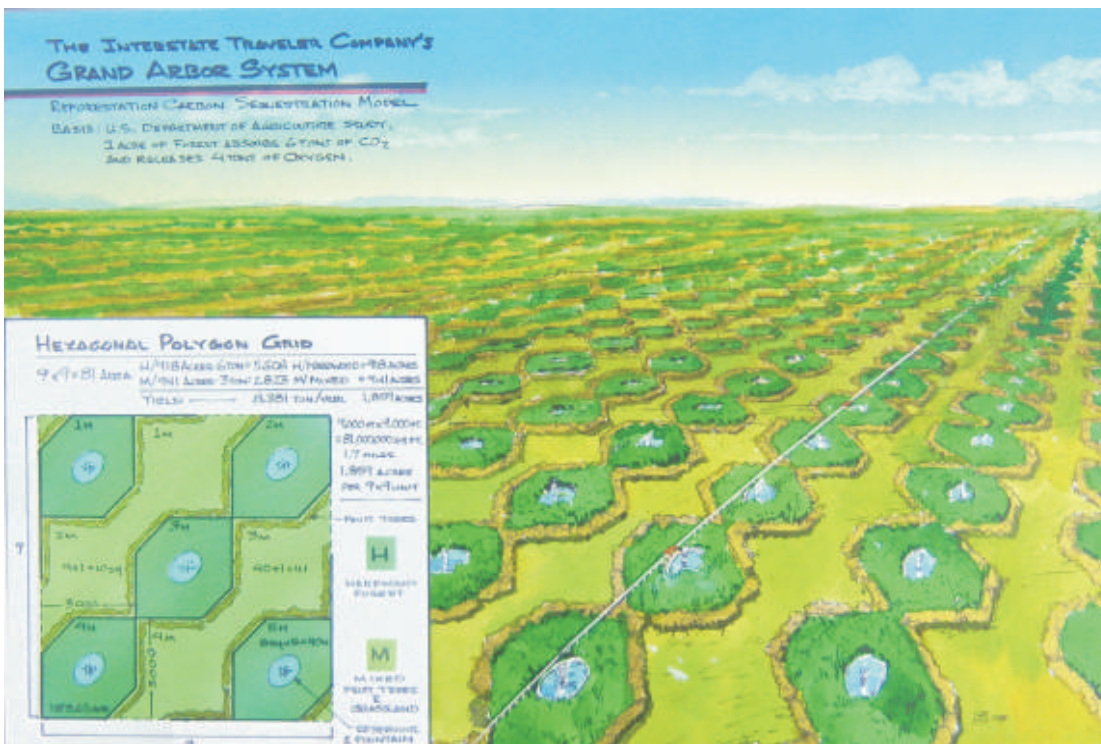



# Round-About

The safest way to handle roadway intersections.

Looking forward to safer roads and the replacement of typical road way intersections where traffic lights direct the flow of traffic in an unreliable and inefficient manner, the Round-About is becoming more prevalent. Studies have shown that traffic lights waste time and fuel and create a false sense of security that leads to fatal car accidents by the thousands.

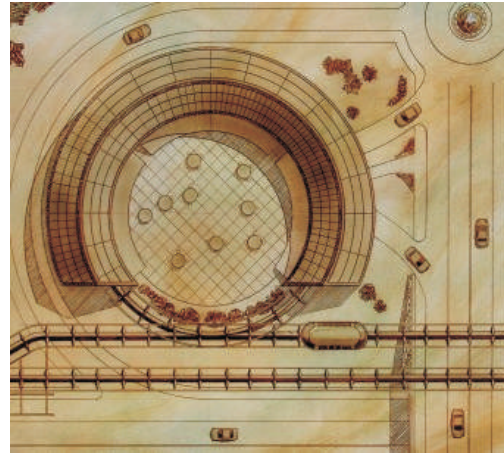

The Hydrogen Super Highway is a natural fit for all Round-Abouts large and small and will safely transition maglev transports to and from intersecting rail networks safely and with quickness.

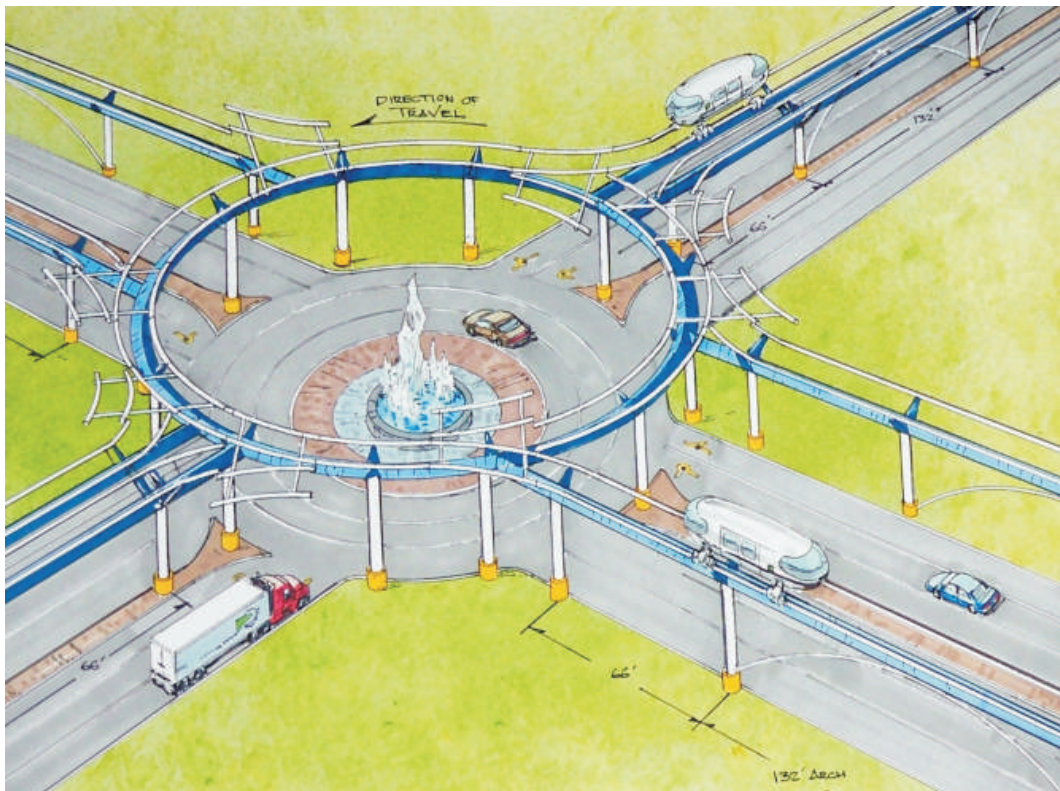

Fast

Efficient

Safe



# Optimize Utility Corridors



It has been said for many years that no new highways will be built in America. Well, that may be true, but with the HSH the existing electrical energy "highways" of high-voltage hi-tension lines can be upgraded to move more than just electricity.

Our continents are criss-crossed by thousands of miles of high-tension lines. With the HSH the utility companies that own those lines can reap the benefits from recycling all that bulk metal and reap the benefits of building commercial roads, condos and businesses where they could not exist before...

Even Rail Roads will also be able to reap the benefits. The hundreds of thousands of miles of Rail Road rights of way can be quickly upgraded without disturbing the existing heavy rail system that is in place. With the Highways, the High-Tension line corridors, and the Rail Road rights of way all coming on-line together, the greater number of people will be employed and served for generations to come.



Recycle

Reuse

Recuperate

Reinvigorate

New Roads

New Highways

New Villages

New Cities





# Structural Rail Geometry

Huge Load Capacity ... Exceeding 100 Tons

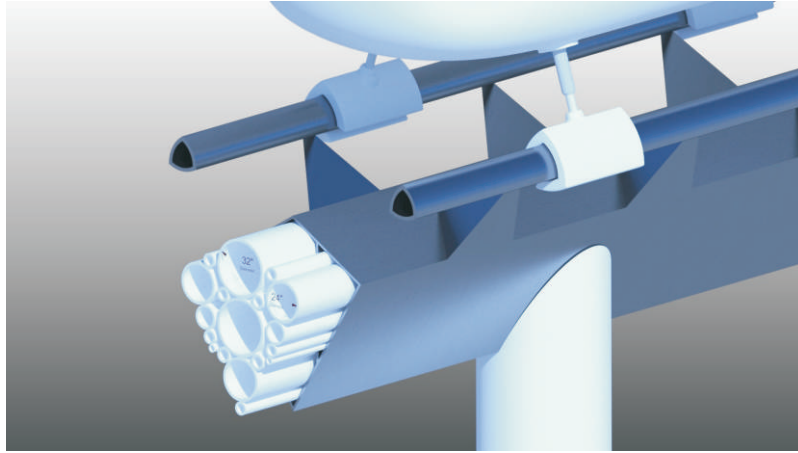

CAD

CAM

FEA

FMA

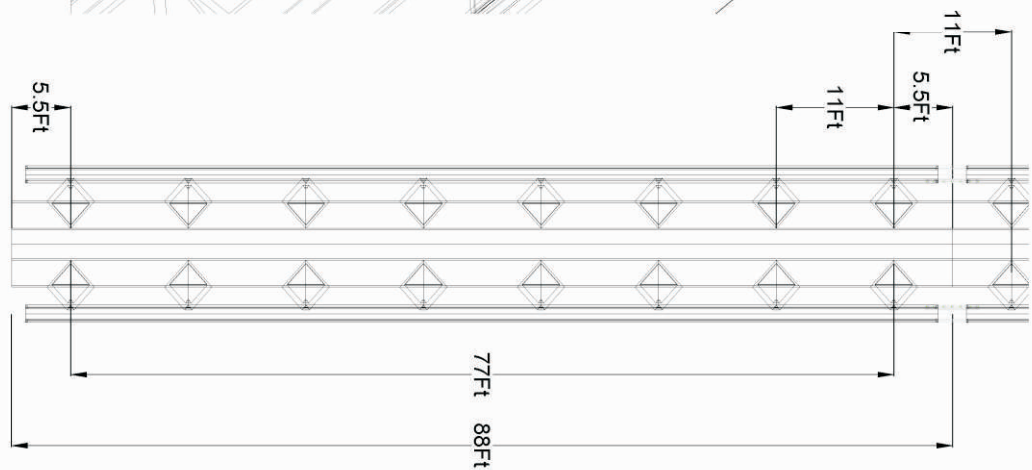
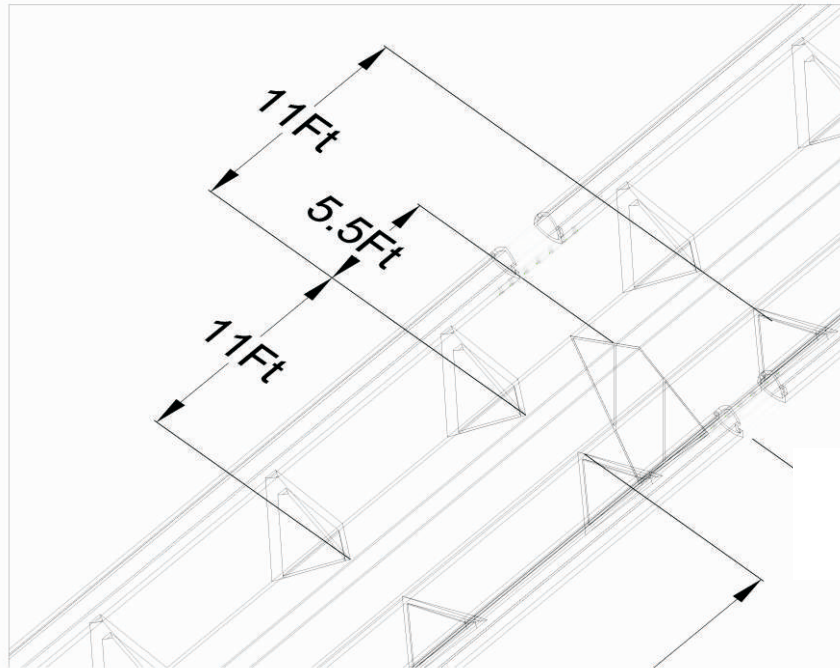

# Dynamic Suspension

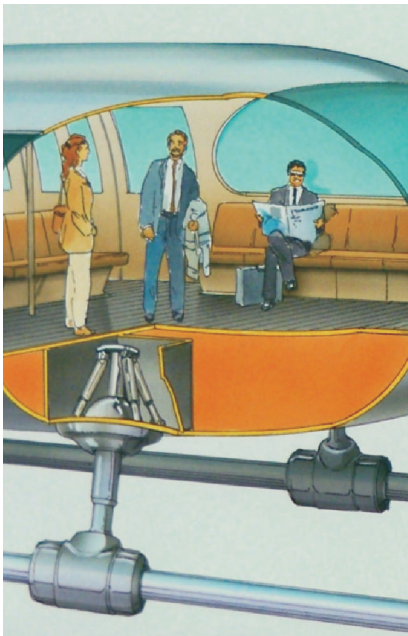

The great and uniquely successful attribute of the Hydrogen Super Highway is G-Force mitigation made possible by our unique ballpoint cantilever suspension system.

Using realtime kinematic feedback from a pendulum or solid state accelerometers, the HSH Transport suspension system can feel the G-Forces from speeding up, slowing down and banking on curves to automatically adjust the three dimensional attitude of the transport keeping the forces perpendicular to the floor.

When it comes to transit rail technology...  
...the HSH will keep you upright.

G-Force Mitigation

Automatic Pitch Control

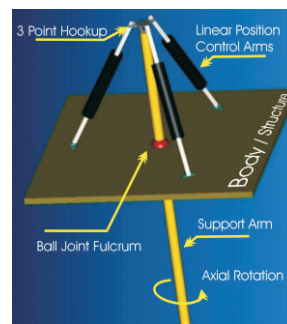
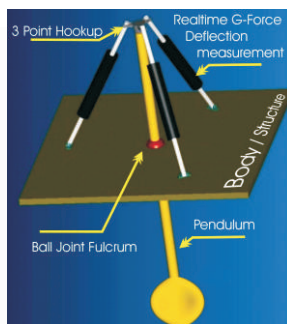
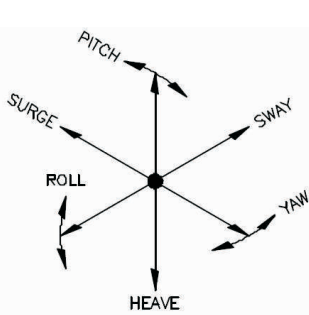
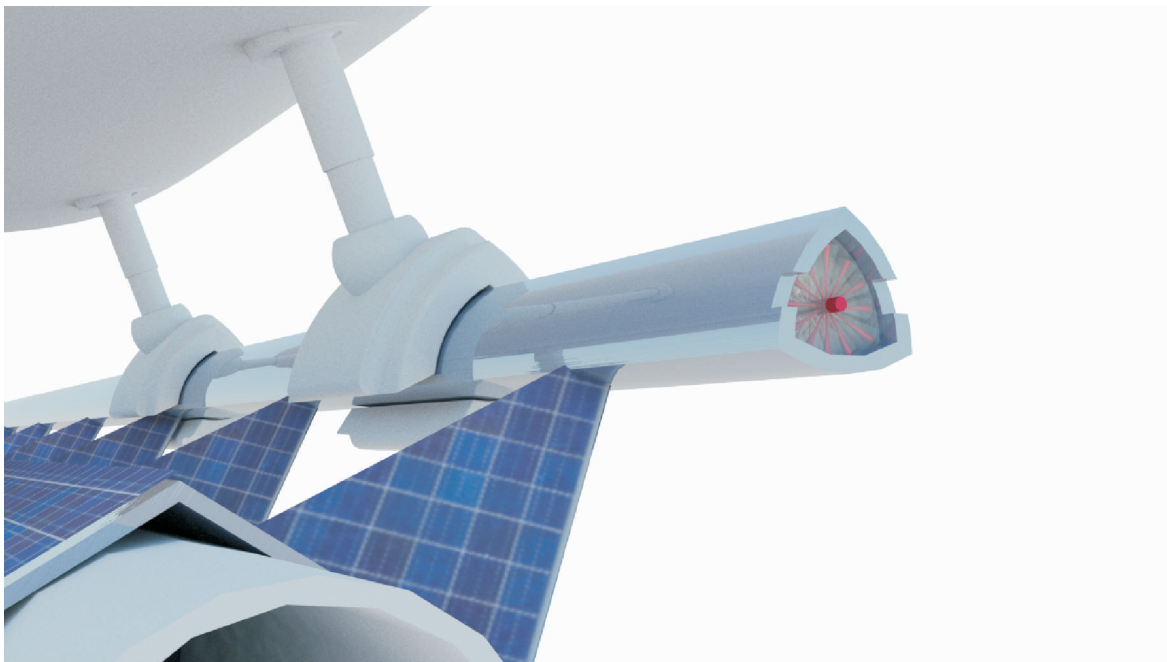



# Magnetic Levitation

The unique and practical application of radially arranged magnetic fields enables the most versatile maglev transportation system possible hosting motors of almost any size and combination.

Whether your transport has two motors, six motors or even twelve, or you own a fleet of 500 freight transports the rail will efficiently optimize any number of motors on any number of vehicles and save you real money.

Powerful

Versatile

Efficient

Quiet

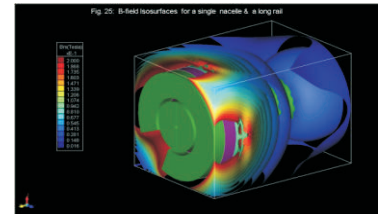
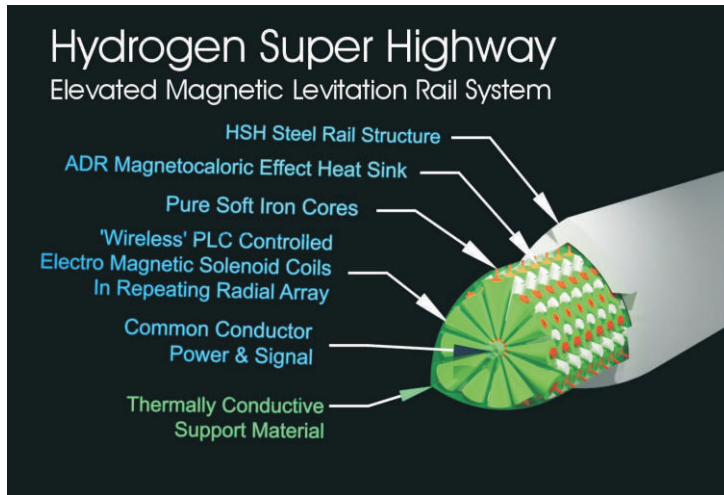

FEA Virtual Load Testing

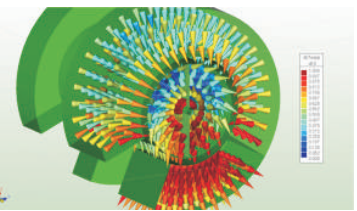

## Interstate Traveler Linear Motor and Levitation Coil Arrangement

### Traveling Wave Linear Propulsion

(One of several methods to employ the ITC Rail Coil Arrangement to provide levitation and position control)

By controlling coil power intensity, the motor can be levitated and pushed along the rail by a traveling intensity wave behind the motor. As the coils radiate from the center of the rail, so too does the intensity wave.

Longitudinal Cross Section of ITC Rail and Motor Nacelle

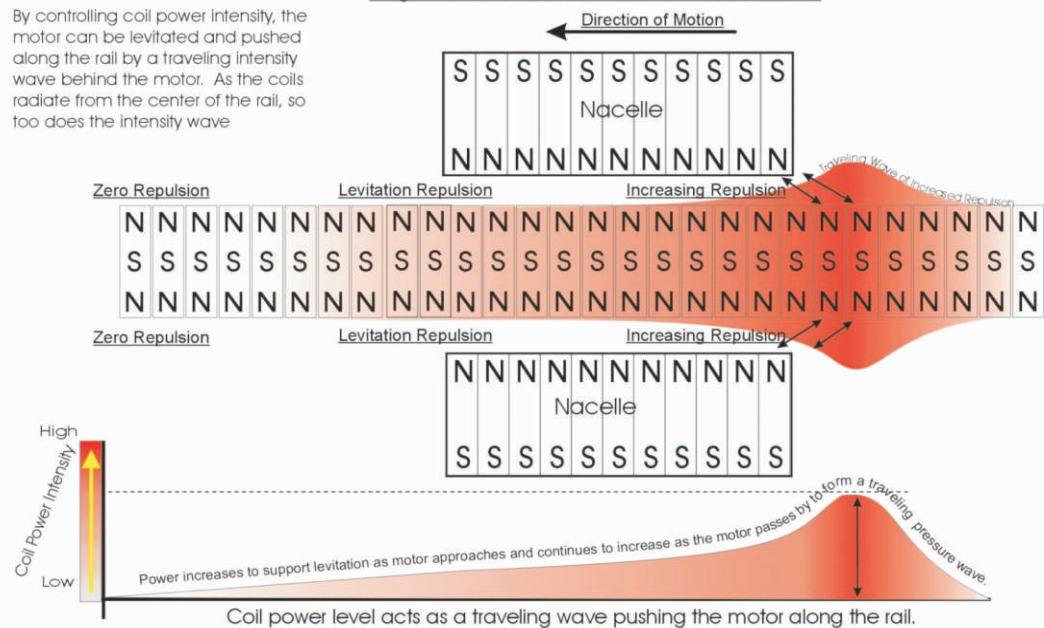

# Rapid Installation

From bedrock to soft soil, the HSH Installation Crane can set up stanchions fast. Using the stanchion poles themselves as giant drill bits we literally can drill our supports directly into bedrock.

With our logistics predicting a combined output of more than 2,000 sections of rail per day when considering the production of 12 factories working together in America resulting in rapid system installation capability and minimal disturbance of the surroundings during the installation process.



With the ability of multiple Rapid Installation Cranes working, the rapid pace of installation ensures an efficient and growing network to serve the needs of people and industry.

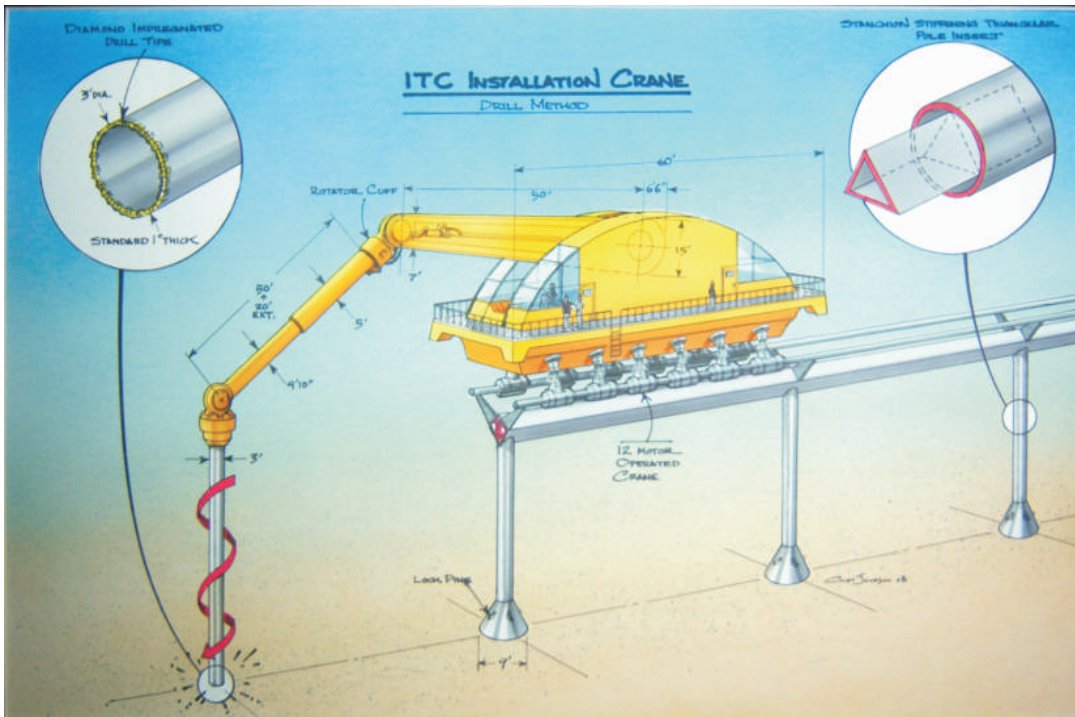

Fast

Automated  
Installation

Any Time

Any Where





# Containerized Freight

The integration with Port Security is clear to see with the fast and simple container transports. As the HSH network expands, so will the access points for Containerized Freight.



One step above containerized freight will be the closed shell flat bed, just big enough to load an 18 wheeler, Tractor and all. You will be able to send your Driver, your Truck and your Freight to any place in the Country without the worries of traffic jams or bad weather.

Traditional freight haulers, air cargo, heavy rail hubs and sea ports will all be linked together creating an even greater national distribution network from Port, to Hub, to Factory to Consumer accelerating our economy globally

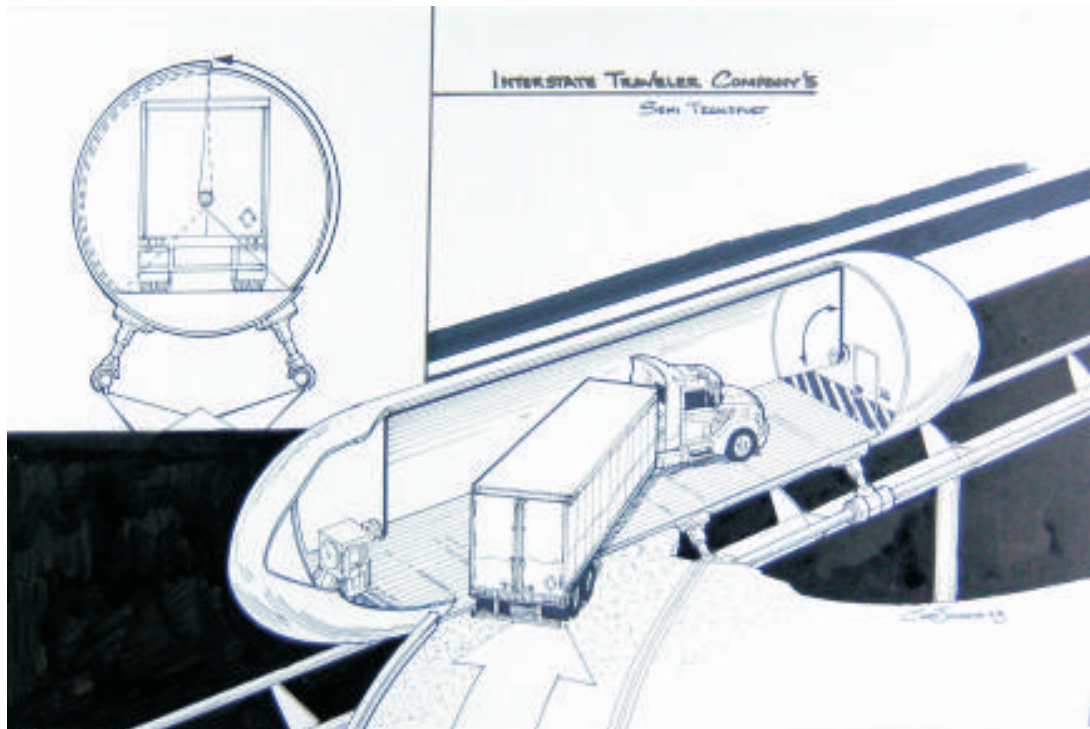

Secure

Fast

Easy to Use

Stable

Reduced Risk







## *Ten Primary Deliverables*

Rapid Transit	= \$ /minute
Advertising	= \$ /sign
Hydrogen	= \$ /kilogram
Electricity	= \$ /kilowatt
Energy Storage	= \$ /kilowatt
Fiberoptics	= \$ /bandwidth
Fuel pipelines	= \$ /gallon or Ft <sup>3</sup>
Liquid waste	= \$ /barrel
Brand New Water	= \$ /liter
Internet / Telecom	= \$ /minute

### *Regional Economic Development*

Long term employment from construction and operations of our rail system will lead to sustained regional economic development as well as stabilization of property values.

The increase in local land values may exceed 200% in some locations and in some places much more.

The presence of reliable transportation and infrastructure that is resilient to earthquakes will attract greater 3rd party investment.



# *The Interstate Highway Network*

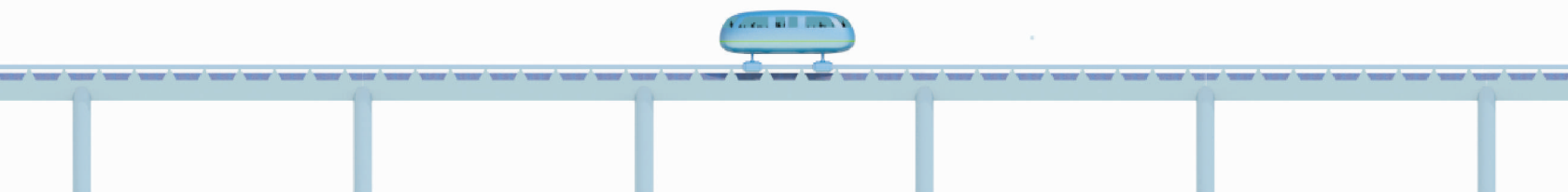
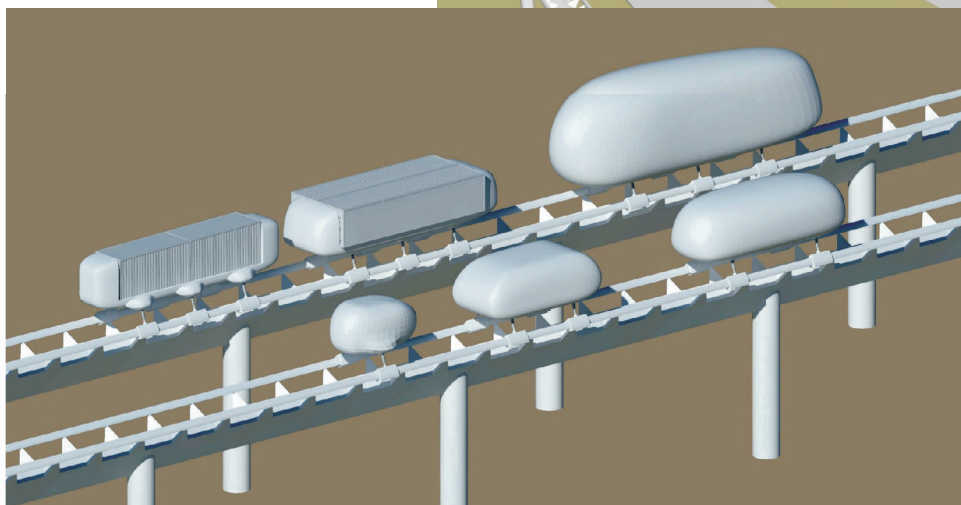
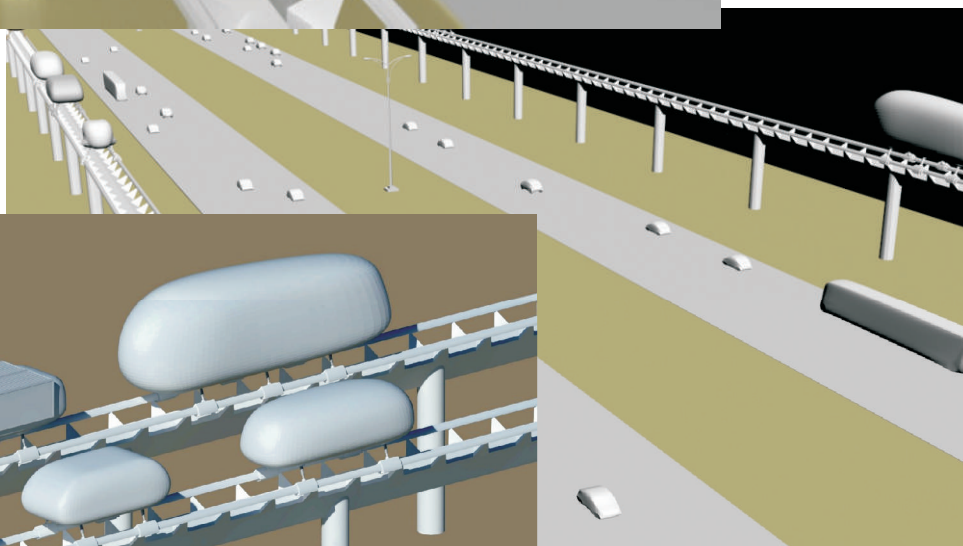
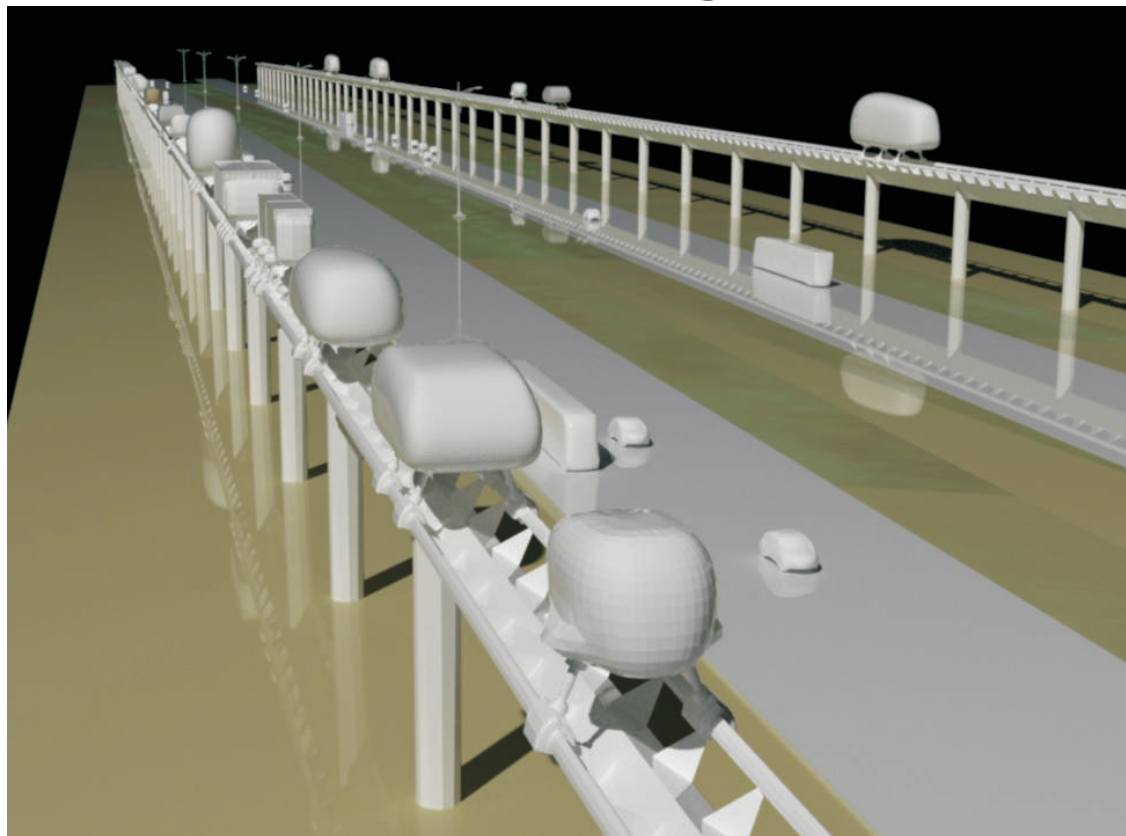

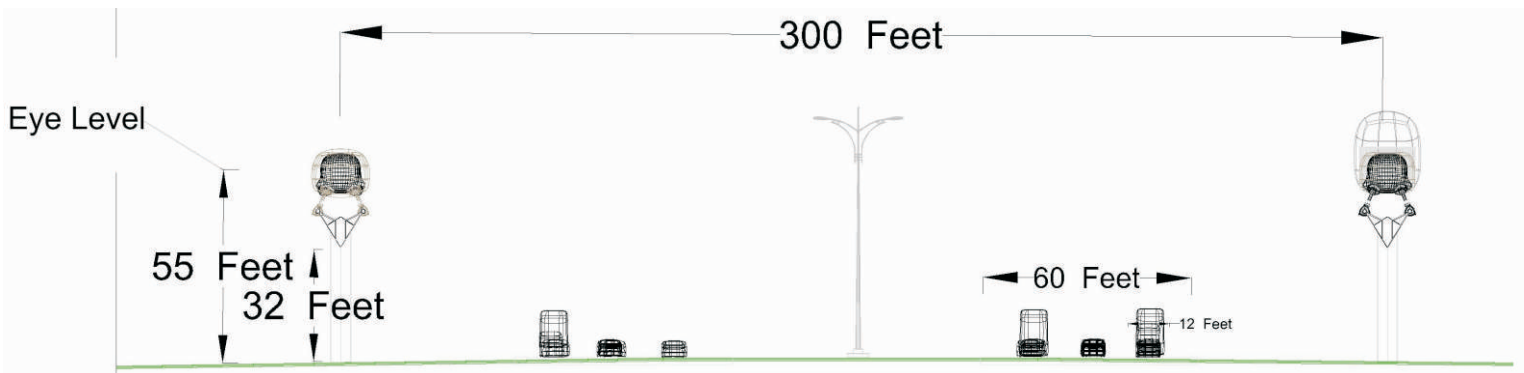
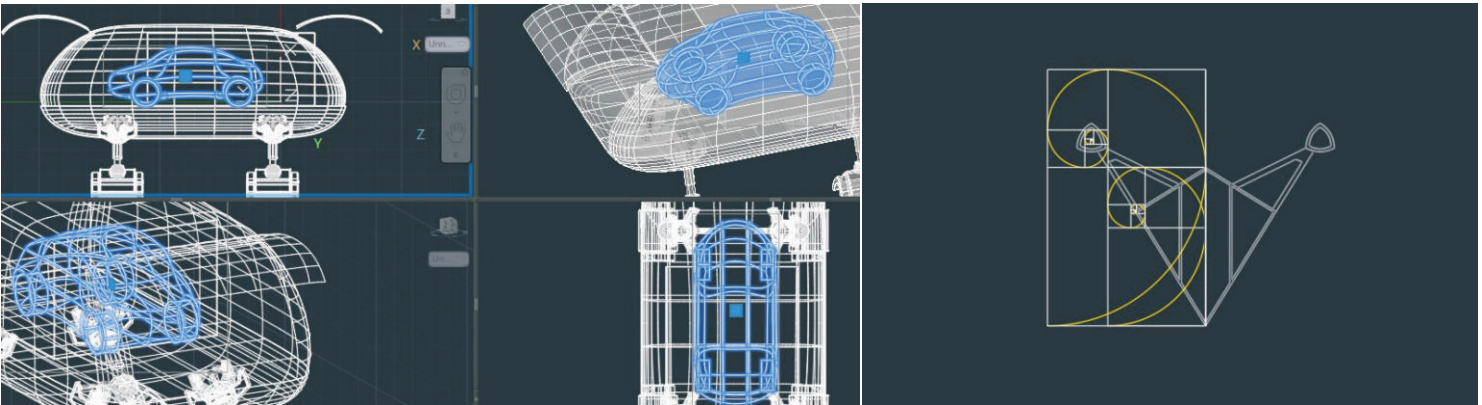
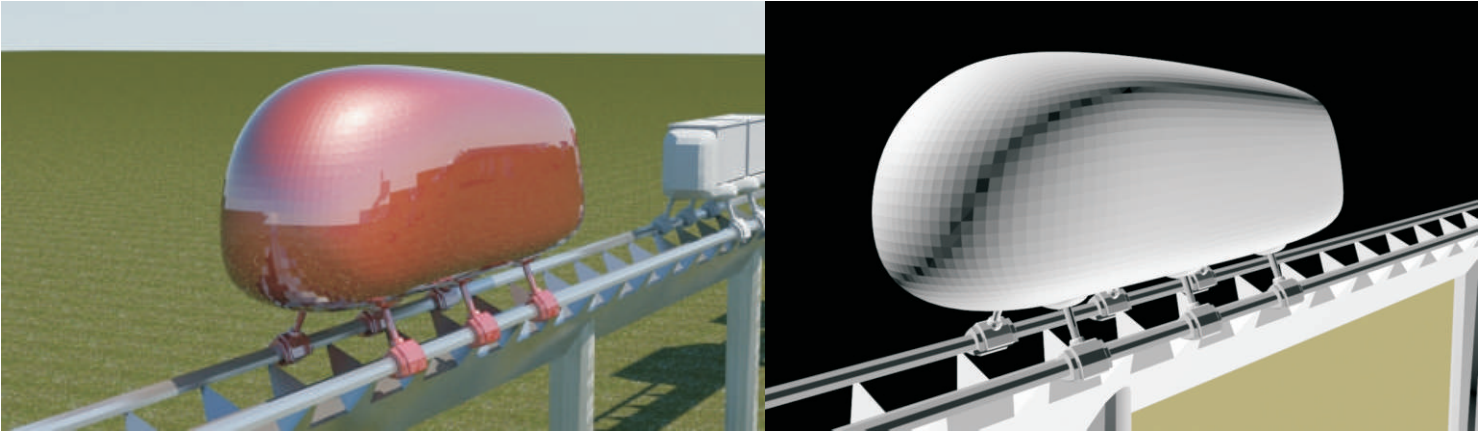
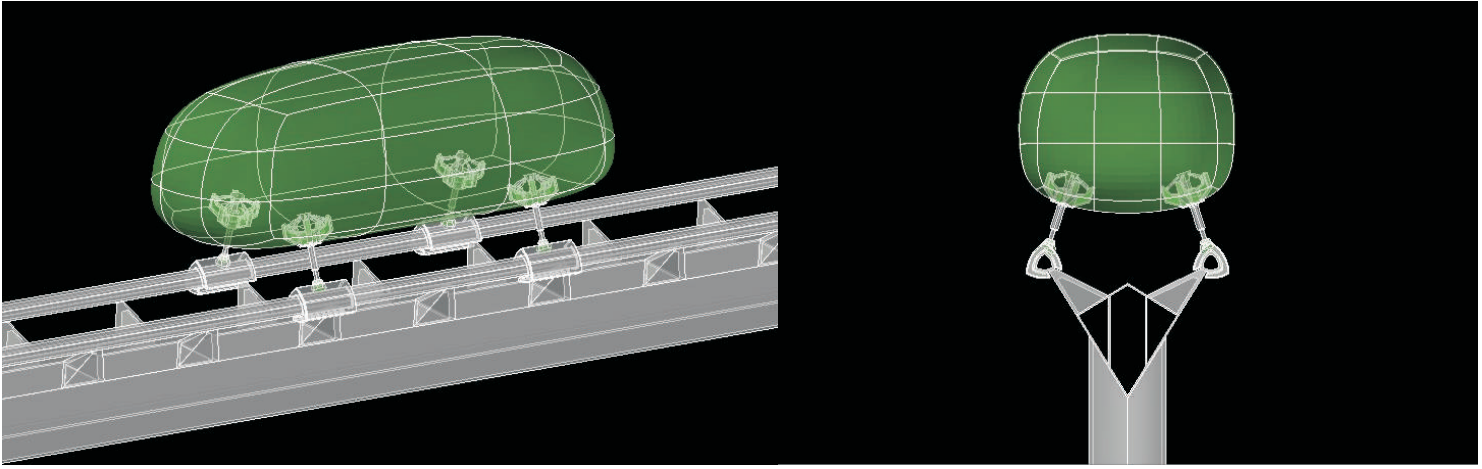

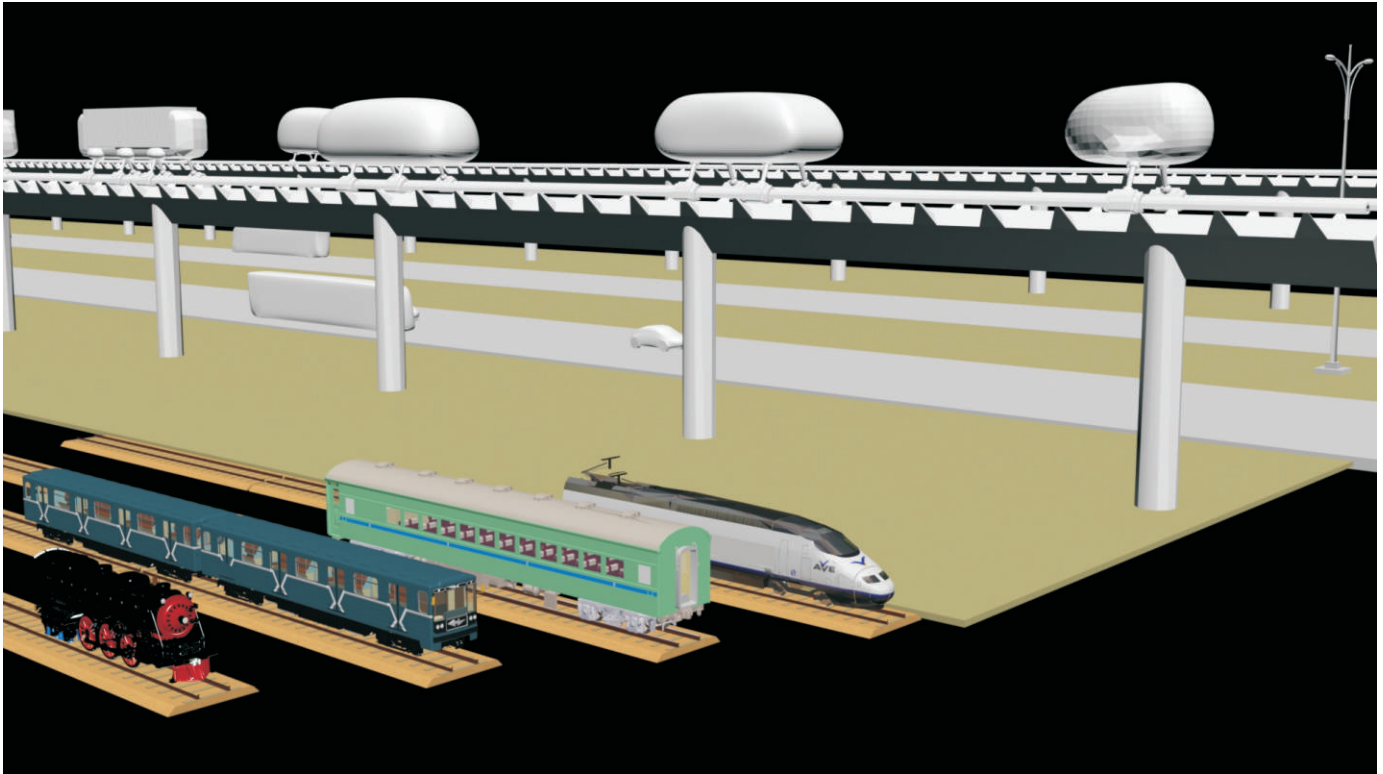

# HYDROGEN SUPER HIGHWAY

THE INTERSTATE TRAVELER COMPANY, LLC

ALL RIGHTS RESERVED

2018